

VORTEX  
THE FORCE OF OPTICS®

# VIPER® PST™ RIFLESCOPE



Second Focal Plane | Uncapped Turrets

**6-24x50 EBR-I RETICLE (MOA)**

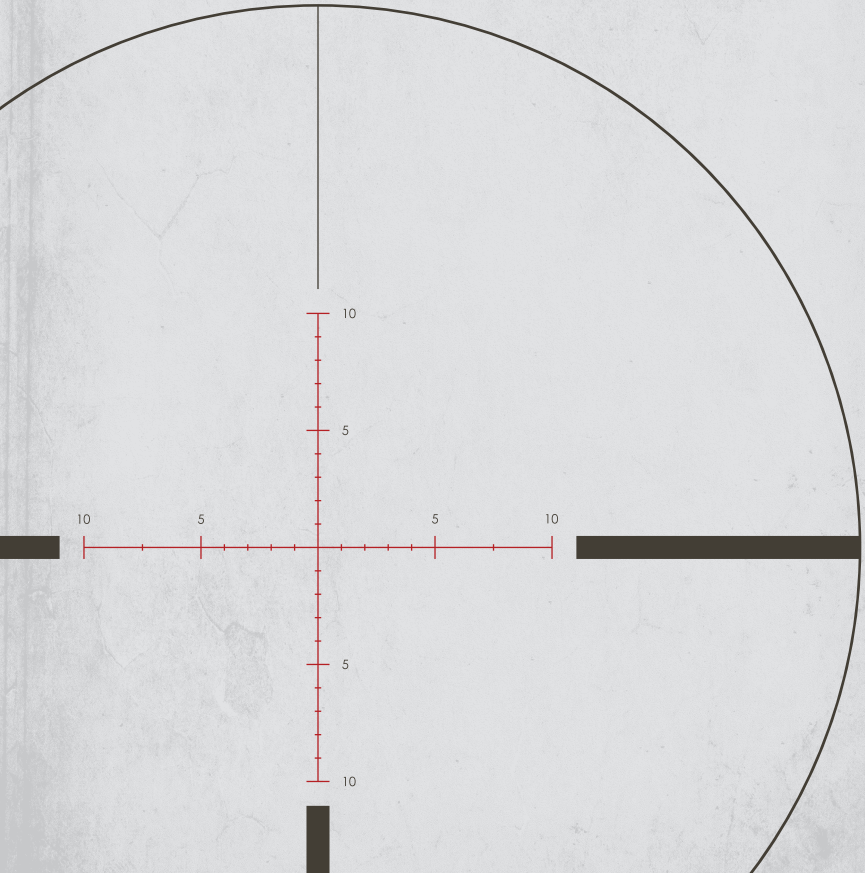

### The Vortex® EBR-1 MOA Reticle

Designed to maximize long distance shooting and ranging abilities, the EBR-1 MOA reticle for the Viper® PST™ 6–24x50 rifle scope can be used to effectively determine ranges, holdovers, windage corrections and moving target leads. Ultra precision laser etching on the glass reticle ensures that minute of angle (MOA) specifications can be kept to the tightest tolerances possible. The fine center crosshair subtensions on the EBR-1 MOA reticle were carefully chosen to provide the optimum balance between precision aiming and low light visibility.

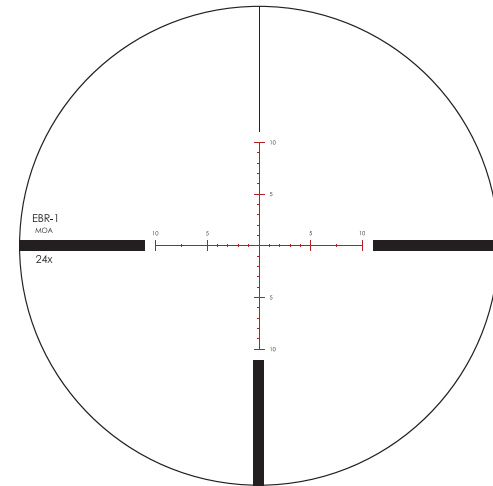

**Note:** Reticle images shown in this manual are for representation only—images vary between scope models depending on magnification and reticle plane.

## MOA Subtensions

The EBR-1 reticle is based on minute-of-angle (MOA) subtensions.

MOA measurements are based on degrees and minutes: 360 degrees in a circle, 60 minutes in a degree for a total of 21,600 minutes. These angular measurements are used to estimate range and correct for bullet trajectory drop in riflescopes. 1 MOA will correspond to 1.05 inches at a 100 yard distance, 2.1 inches at 200 yards, 3.15 inches at 300 yards, and so on.

In the Viper PST second focal plane riflescopes, the listed MOA subtensions of the EBR-1 reticle are only valid at the highest magnifications of the scope. However, by understanding the relationship of magnification and subtensions, ranging, holdovers, and wind drift can still be calculated at partial magnifications. Here are some examples:

- If the magnification is set at ½ the full magnification, subtension values will be two times the spec listed in the manual.
- If the magnification is set at 1/3 the full magnification, subtension values will be three times the spec listed in the manual.
- If the magnification is set at ¼ the full magnification, subtension values will be four times the spec listed in the manual.

### Estimating MOA

Although 1 MOA is very commonly corresponded to 1 inch at 100 yards, this is not quite correct. 1 MOA at 100 yards equals 1.05 inches. Calling 1 MOA an inch per 100 yards may be acceptable at shorter distances, but it will cause a five percent error in ranging and holdover adjustments. This will result in missed shots at longer distances.

## EBR-1 MOA Reticle Subtensions

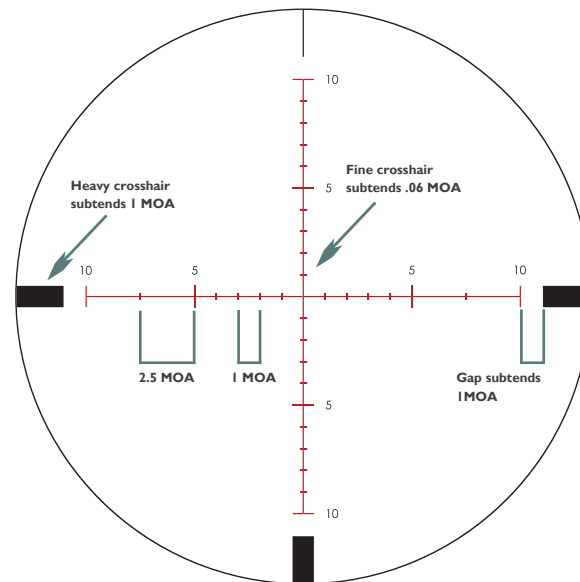

### Subtension Changes with Magnification 6-24x50 Reticle Subtensions (Valid at 24x)

RIFLESCOPE MAGNIFICATION	ACTUAL SUBTENSION OF 1 MOA RETICLE SPACE
24x	1 MOA
12x	2 MOA
8x	3 MOA
6x	4 MOA

## Ranging

MOA measurements are very effective for ranging using a simple formula. To use this formula, the shooter needs to know the size of the target or nearby object in inches.

### MOA Ranging Formula

$$\frac{\text{Target Size (Inches)} \times 95.5}{\text{Measured MOAs}} = \text{Range (Yards)}$$

Using either the vertical or horizontal MOA scale, place the reticle on a target of known dimensions and read the number of MOAs spanned. You will obtain maximum accuracy in ranging by calculating exact MOA measurements. MOAs should be estimated in 1/4s if possible.

Accurate measuring will depend on a very steady hold. The rifle should be solidly braced using a rest, bipod or sling when measuring. Once you have an accurate MOA reading, use the formula to calculate the distance.

**Note:** In the MOA ranging formula, a shooter may substitute **100** for **95.5** in the interest of speedier calculations. Be aware that this will produce a five percent *over-estimation error* of the yardage distance obtained.

### Example

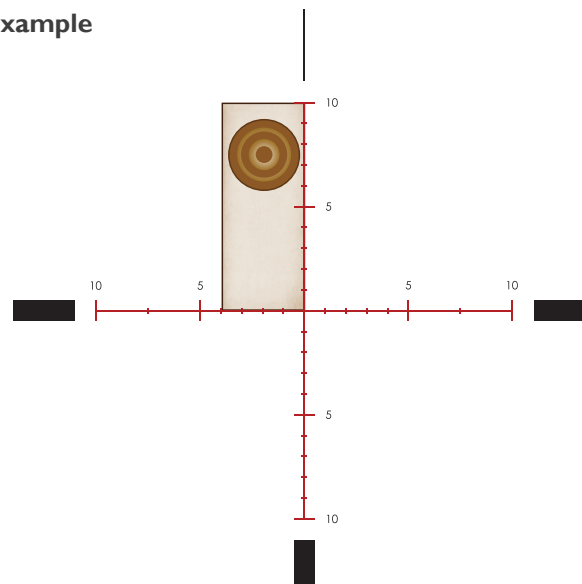

Ranging a 6-foot target (72 inches) at 10 MOAs yields 688 yards.

$$\frac{72 \times 95.5}{10 \text{ MOA}} = 688 \text{ Yards}$$

## Elevation Holdovers

Once the distance has been calculated using the EBR-1 MOA reticle, or a laser rangefinder, the EBR-1 can be used for rapid holdover correction for bullet drop of the cartridge being used. To get the most benefit out of the EBR-1 equipped riflescope, Vortex Optics highly recommends shooters learn their bullet drop numbers in MOAs rather than inches.

Since the EBR-1 reticle is scaled in 1 MOA increments, it is an easy job to quickly select the correct drop reference line once the shooter knows the bullet drops in MOAs. If the shooter prefers to dial *come ups* for bullet drop using the elevation knob, knowing bullet drops in MOAs rather than inches will allow for much faster adjustments as the MOAs can be quickly read on the elevation knob.

### Example

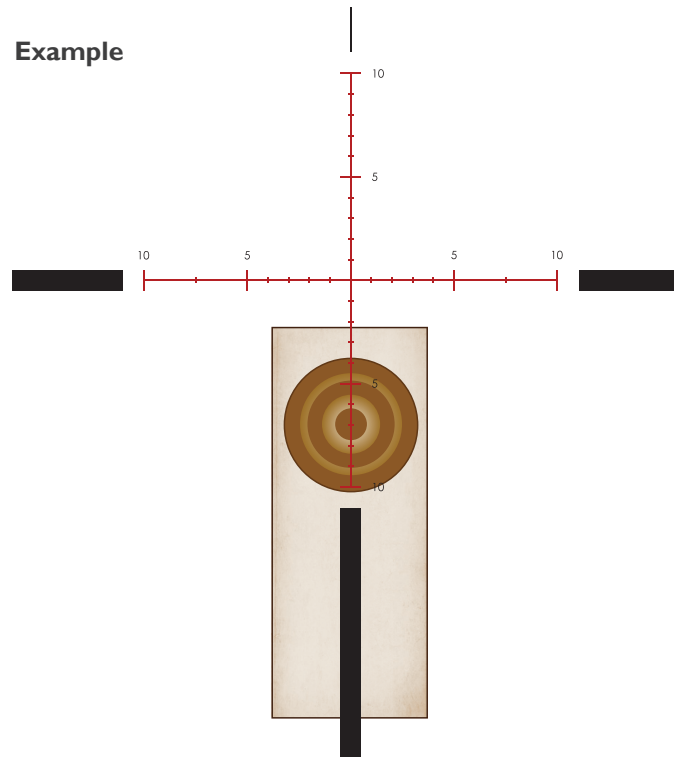

7 MOA reticle holdover at 400 yards. No wind.

## Windage and Moving Targets

The EBR-1 MOA reticle is highly effective when used for wind and moving target leads. Using the reticle for effective windage and moving target leads will require thorough knowledge of your weapons system's ballistic performance under varying conditions and experience in reading wind strengths and target speeds. As in bullet drops, it is important for the shooter to learn a particular weapon's windage/moving target corrections in MOAs rather than inches. Always hold the reticle into the wind.

### Basic windage correction on center crosshair

When dialing elevation *come ups*, the center horizontal crosshair will be used for windage or moving lead corrections.

### Example

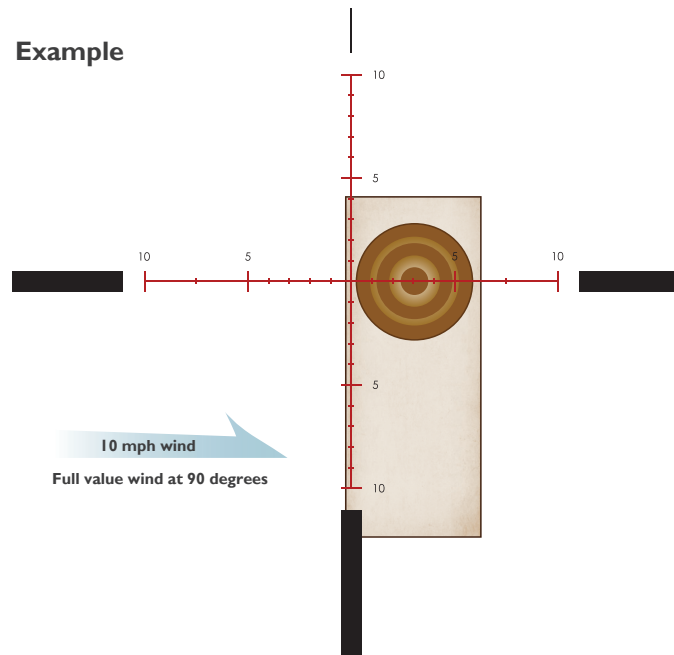

3 MOA reticle windage correction at 400 yards in 10 mph crosswind using center crosshair. Elevation adjustment already dialed into the rifle scope.

### Basic windage correction using drop line on reticle

When using the reticle for elevation correction rather than dialing, the MOA marks on the center horizontal crosshair can still be used to help visually reference windage corrections. Remember to hold the reticle into the wind.

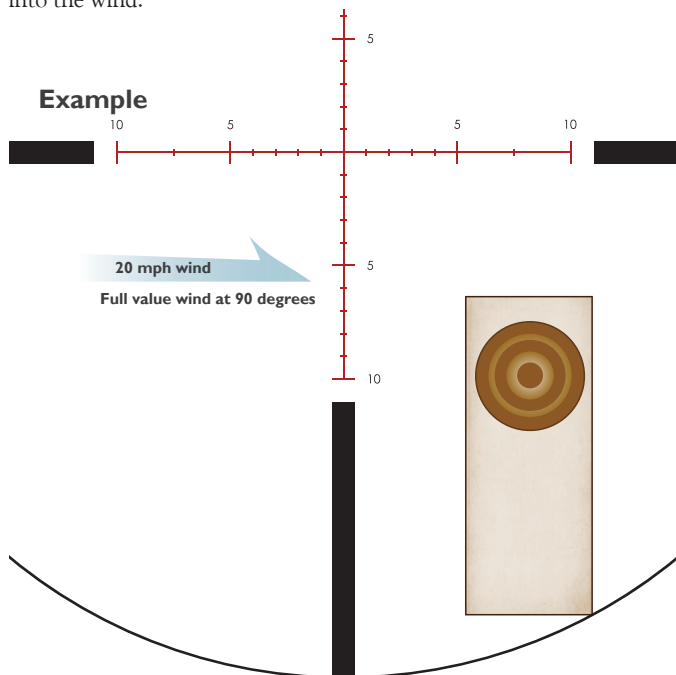

8 MOA reticle windage correction at 500 yards in 20 mph crosswind using 10 MOA reticle drop line.

### Basic moving lead correction

When estimating moving target leads, the MOA marks on the center horizontal crosshair can be used. Estimating moving target leads will require knowing yardage distance, wind speed, moving target speed, and total bullet flight time (including rifle lock time). Bullet flight times can be roughly calculated based on fps velocities or a ballistic calculator.

**Note:** Correctly estimating moving leads is very difficult and requires considerable practice and knowledge beyond the scope of this manual.

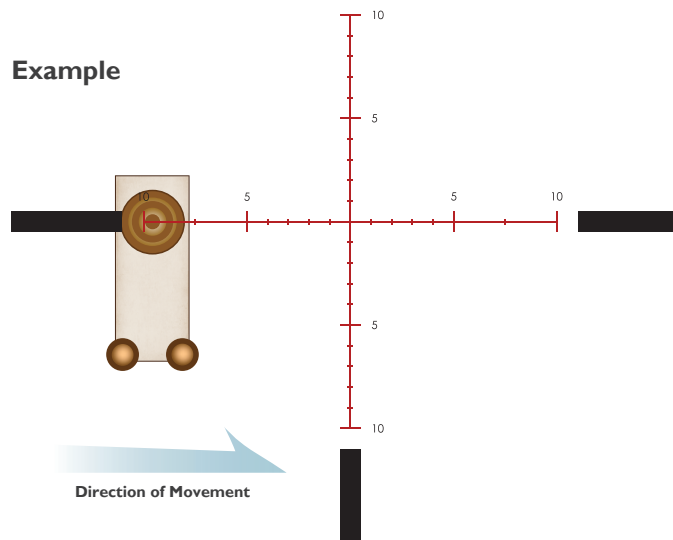

9.4 MOA reticle correction for a target moving 3 mph at a distance of 800 yards. No wind. Total bullet time of flight from trigger pull is 1.5 seconds during which target travels 6.6 feet. Elevation already dialed into turret.

## THE VIP WARRANTY

We build optics based on our commitment to your absolute satisfaction.

That's why Vortex products are unconditionally guaranteed and we make this Very Important Promise to you—a Very Important Person.

Rest assured that in the event your Viper PST becomes damaged or defective, Vortex Optics will repair or replace the riflescope at no charge to you. Call Vortex Optics at 800-426-0048 for prompt, professional, and friendly service.



Vortex Optics  
2120 West Greenview Drive  
Middleton, WI 53562  
service@vortexoptics.com

Visit [www.vortexoptics.com](http://www.vortexoptics.com) for more information. Canadian customers may visit [www.vortexcanada.net](http://www.vortexcanada.net) for customer service information.

**Note:** The VIP warranty does not cover theft, loss, or deliberate damage to the product.



**VORTEX**  
THE FORCE OF OPTICS®

**VIPER® PST™**  
**RIFLESCOPE**



[WWW.VORTEXOPTICS.COM](http://WWW.VORTEXOPTICS.COM)

#PST-R624SI-A-12A

© Vortex Optics USA