

SCHMIDT BENDER

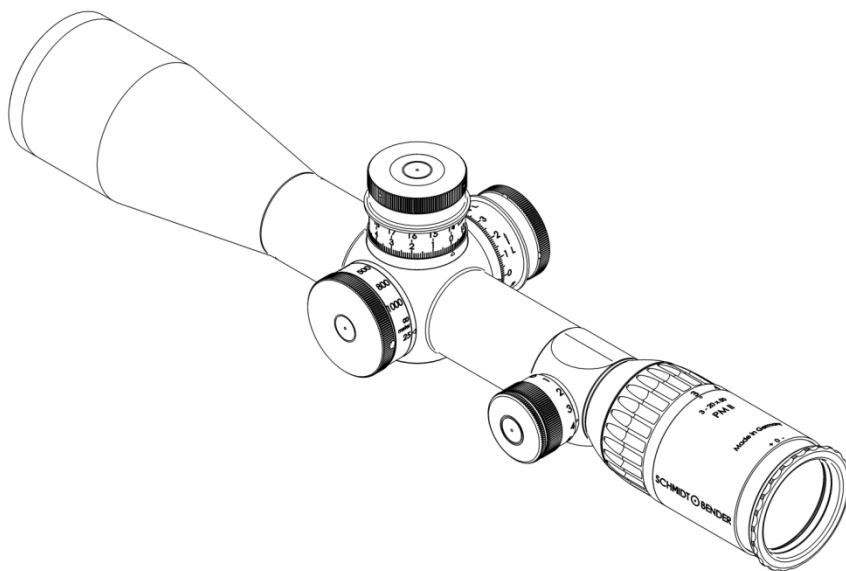

3-20x50 PMII
5-25x56 PMII

1. Operating instructions

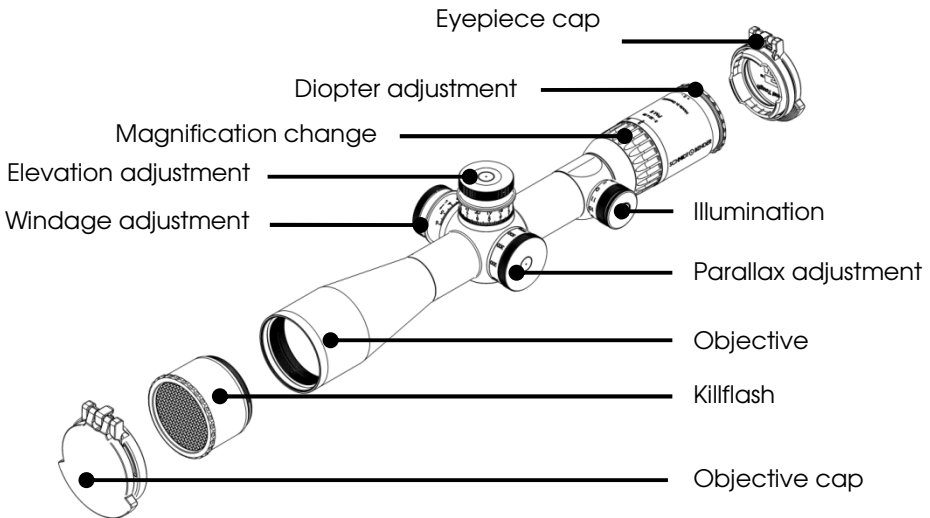

Fig. 1 Operating Controls and Accessories

1.1 Using the MTC Locking Turrets

The MTC LT turrets include the following features:

- Double turn (elevation)
- MTC (more tactile click)
- Zero stop (elevation and windage)
- Locking function (elevation and windage)

The „double turn“ elevation turret provides a fine click adjustment value in addition to a large elevation adjustment . When the turret is rotated into the second revolution a small cylinder pops up on top of the turret which indicates to the user that the second turret revolution has been reached. (Fig.)

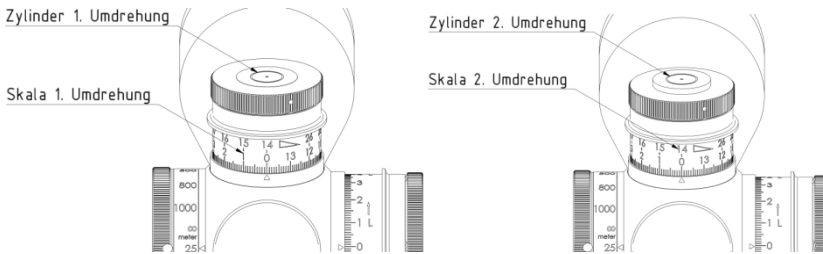

Fig. 2 First Turret Revolution and 2nd Turret Revolution Indicator

Additionally, the zero stop function supports the quick adjustment to the zero position. The zero stop function is determined by an end stop. The MTC elevation turret has an audible "clunk" on every 10th click.

The elevation and windage turret include a locking function which prevents the inadvertent adjustment of the turret. To lock the turret, the outer flange with the engraving must be pushed down in direction of the scope tube until "LOCKED" appears on the turret (Fig.). To unlock the turret, the outer flange must be pulled up until the "LOCKED" indicator completely disappears (Fig.).

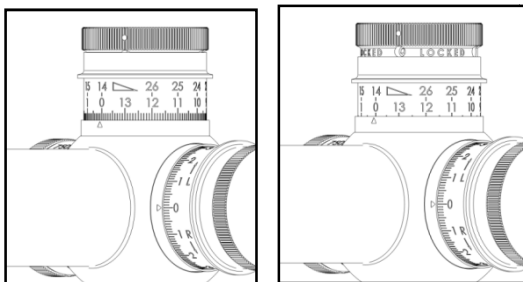

Fig. 3 Locked and Unlocked Positions

1.2 Zeroing the scope

When sighting in the scope for the first time, or re-sighting the scope due to service or repair the elevation and windage adjustment must be recalibrated. Therefore a test shooting on a target in (at) the reference distance in which the scope shall be zeroed must be performed. The deviation from the center of the target or point of aim is then corrected.

The centering of the shot pattern is finally confirmed by another test shooting. If the deviation from the center of the target or point of aim continues to exist please repeat the procedure.

To adjust the turrets, lock both turrets, elevation and windage, loosen the two Allen screws located at 9 and 3 o'clock **ONLY (see caution below)**.

Loosen ½ turn in the outside diameter in line with the "LOCKED" text using an Allen key. Now unlock the turrets by pulling up the outer bushing with the engraving and turn both turrets until the engraved "0" is indicated by the triangle on the saddle. The clicks of the turrets can be felt and heard when the screws are unlocked. This has no impact on the process of zeroing as the reticle does not move while the setscrews are loose.

Lock the turrets by pushing down the outer bushing with the engraving and tighten the two Allen head screws with an Allen key. Tighten set screws gradually with equal amount of turn on the Allen set screws – do NOT over tighten, this could cause internal damage.

- ① The elevation turret must be in the first revolution. The turret caps are secured by an additional screw that should **never** be removed by the user, otherwise the entire turret will come off and readjustment of the MTC pins is very difficult. Unlike other Schmidt & Bender turrets, this retaining screw should only be removed by a trained Schmidt & Bender technician. Removal of this retaining screw may result in the malfunction of the Elevation turret. The clicks of the turrets can be felt and heard when the screws are unlocked. This has no impact on the process of zeroing as the thread piece does not move while the setscrews are loose.

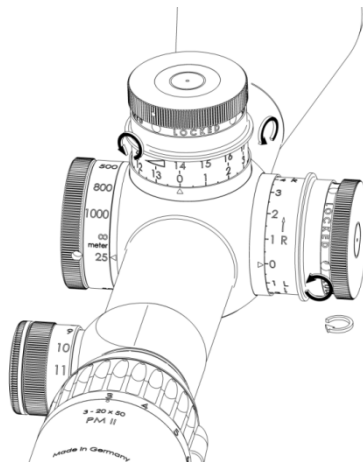

Fig. 4 Allen Head Screw Rotation